

**CARATTERISTICHE
TECNICHE**

C1

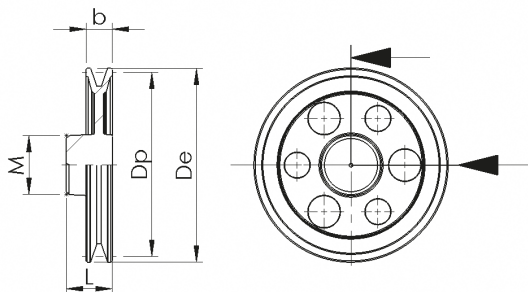

costruzione a cartella con 6 fori

C2

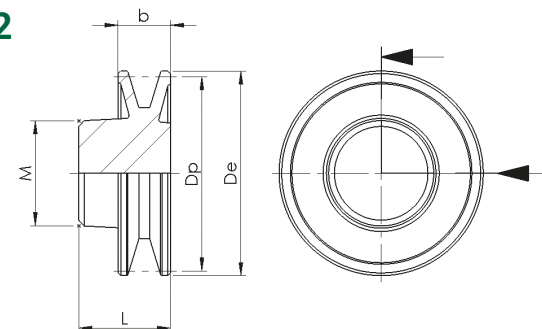

costruzione a cartella piena ribassata

C3

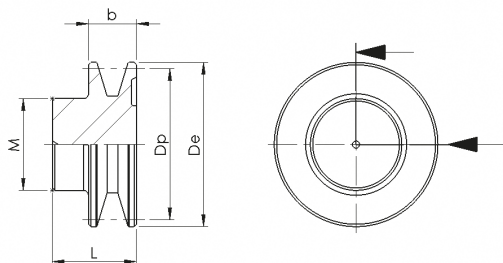

costruzione a cartella piena

C4

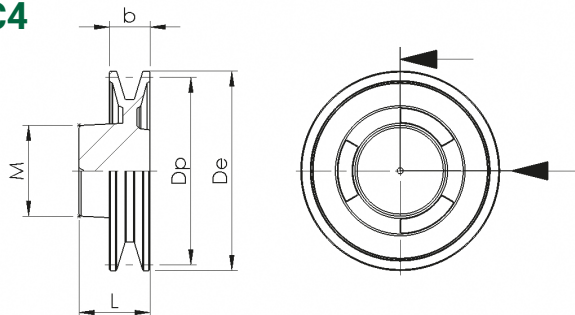

costruzione a cartella a 3 settori pieni e 3 vuoti

C5

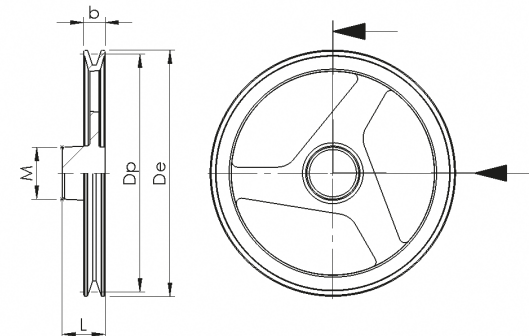

costruzione a 3 razze equidistanti

C6

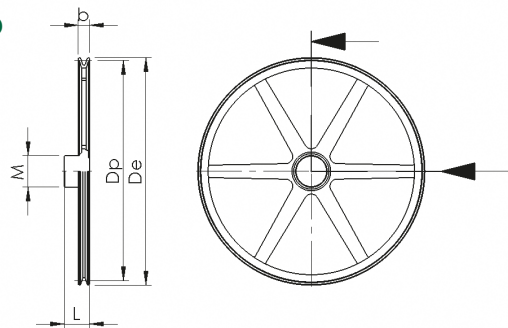

costruzione a 6 razze equidistanti

G2

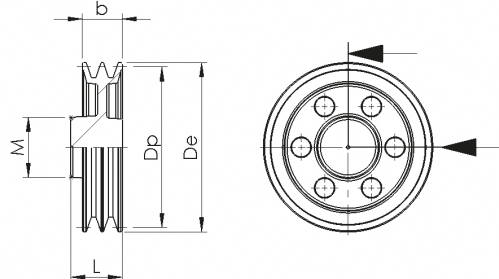

costruzione per pulegge a 2 gole

G3

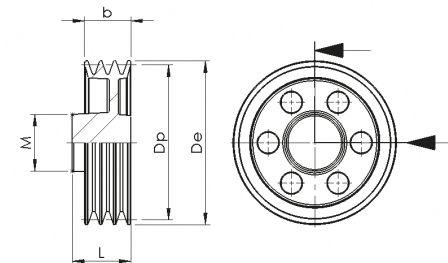

costruzione per pulegge a 3 gole con cartella fuori asse

